



DIGITAL

Bure™

Walker

Bure Double 2.0 56-303

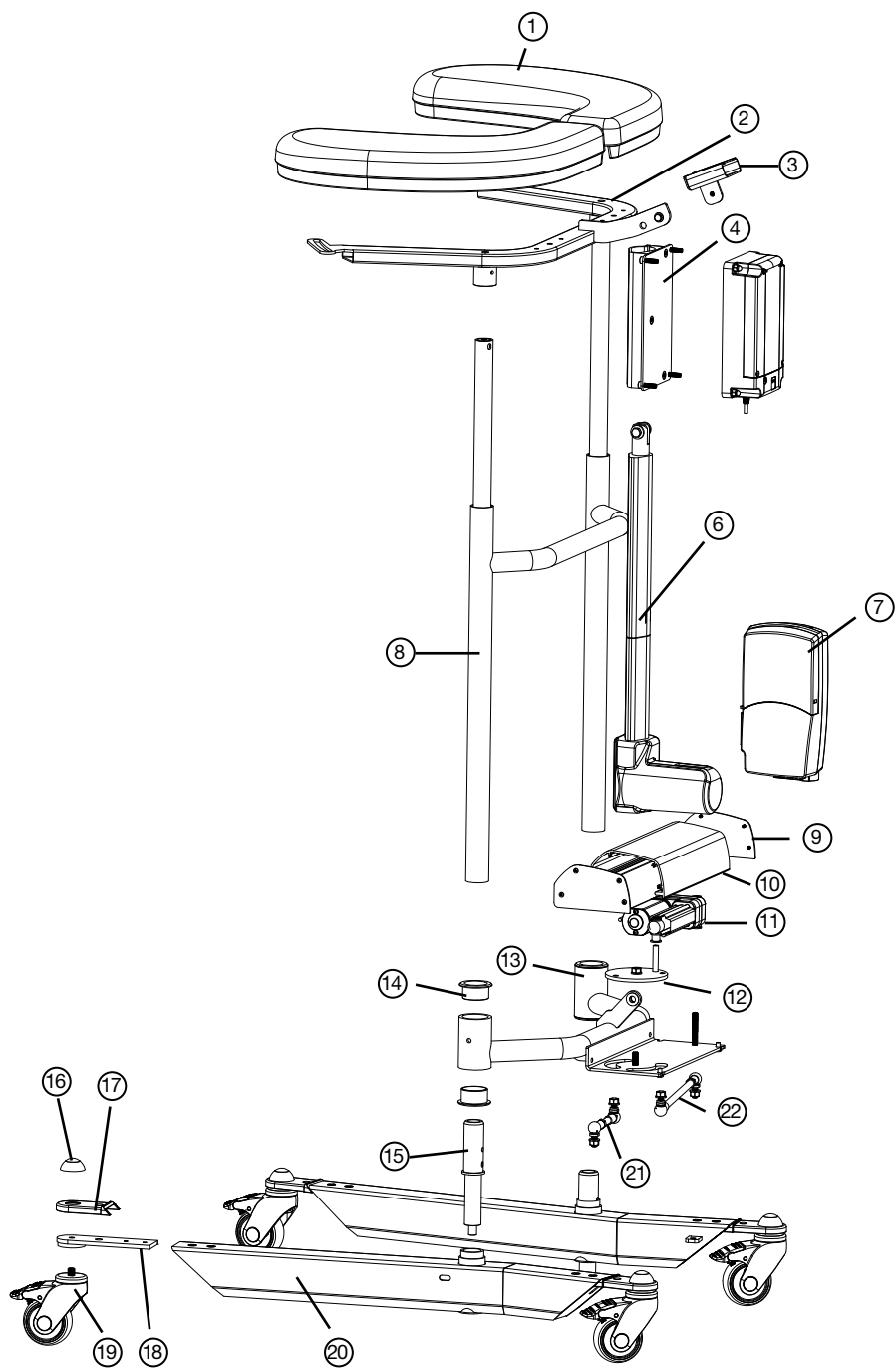

Replacement parts list

1	57-306	Armrestpad left	11	58-378	Actuator, widening
	57-305	Armrestpad right		(TiMotion)	
2	58-365	Frame/Armrest	12	58-364	Circular plate
3	57-041-3	Holder, Remote-control (TH7)	13	58-352	Cross section
4	57-369	Clamp/Battery (alu)	14	58-302	Bearing (x2) Cross section
	57-370	Plate Clamp/Battery (alu)	15	58-353	Turn axle, beam
5	58-376	Battery, TiMotion	16	57-776	Cover, Wheel
6	58-377	Actuator, TiMotion		57-775	Washer, wheel
7	58-373	Controlbox 220V, TiMotion	17	58-360	Cover, Wheelplate (PA)
	58-373-1	Controlbox 110V, TiMotion	18	58-354	Wheel mount beam
8	58-366	Vertical frame	19	57-051	Wheel 75mm
	58-335	Telescopic Innertube incl. Bronzebearing		57-319	Wheel 100mm
9	58-358	Sideplate (2x) alu	20	58-379-L	Wheel 125mm
10	58-356	Aluprofile, widening		58-379-R	Bottom beam, left
			21		Bottom beam, right
			22		Linking arm, right
					Linking arm, left

Accessories

Part no.	Description
	Manual brake, 2handles
	Manual brake, 1handle
56-333-DB	Standing plate, Short
56-383-DB	Standing plate, Long
56-334	Dripstand, Chromed
56-335	Holder for Dripstand
56-336	Oxygen tubeholder
56-337	Side support
56-338	Dripstand holder, Complete
	Kneesupport
56-387	Wheel w brake 75 mm
56-358	Wheel w brake 100 mm
56-361	Wheel w brake 125 mm
57-361-L	Armrestpad PUR left
57-361-R	Armrestpad PUR right
58-374-2	Remote Control (TH7)
56-062	Remote Control PLUS, DB (TH10)
58-320 (-1, -2, -3)	Cable/EUR (-UK, -US, -AUS)
58-326 (-1, -2, -3)	Coiled Cable/EUR (-UK, -US, -AUS)

Electrical system – Technical data

Actuator	Lift	Widening
Producer	T-Motion	T-Motion
Voltage	24V	24V
Push	2000N	1000N
Pull	2000N	1000N
Selflocking push	1000N	1000N
Current	4,6 A	2,8 A
Colour	Black	Black
Stroke	400mm	55mm
Mounting dim	605mm	167mm
Encapsulation	IP66	IP66

IEC 60601-1 3rd revision

Controlbox + Battery

Producer	T-Motion
Voltage	24V
Capacity	2,0 AH
Encapsulation	IP66
Colour	Black
Electrical safety	Class II (Doubleinsulation)

IEC 60601-1 3rd revision

Remote Control Plus

****1.** Service indicator – flashes red after 11 months' operation. Constant light (red) after 12 months' operation. The indicator is a reminder to review the maintenance instruction (see Instructions for Use/Technical Manual. This should be done at least once every 12 months.

Reset: hold down buttons <2a> + <2b> for at least 30 seconds.

******The indicator will go out around 30 seconds after the remote control is activated (battery conservation function).

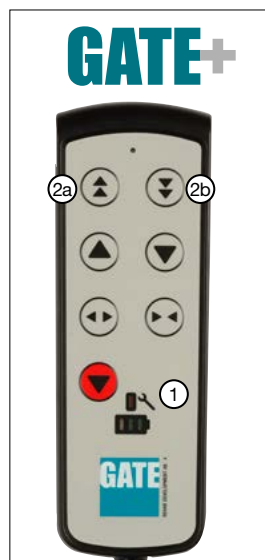

Control box wiring



Remove the control box cover to make the connections as described below. Use a screwdriver or similar; refer to the special labels on the control box.

NOTE! Make sure that plugs are connected to the correct sockets otherwise the actuators can be damaged.

1. Socket for the height adjustment actuator.
2. Socket for the width adjustment actuator.
3. Remote control socket.
4. Battery terminal socket.
5. Plug socket (**NOTE!** Plugs must **ALWAYS** be connected to the control box for IP classification to be valid).

Battery charging

- Connect plug to 230V wall socket. Charging begins automatically and the battery LED flashes green.
- Make sure the battery is fully charged before using for the first time. It takes around 25 h to fully charge the battery.
- We recommend that the battery plug be removed from the control box if the product will be out of use for an extended period (more than one week) or if the battery is switched off by means of the ON/OFF switch. This eliminates the risk of disabling the battery as the control box always uses a small quantity of electricity even when the walker is not in use.

LED on controlbox and battery

- Control box – green light when power is available from battery/mains socket.
- Battery:
 - The LED flashes green during charging.
 - ON/OFF: To use the product, press ON.
 - The green lamp will begin to flash.
 - Use the OFF button (hold down for 5 s) to switch off the battery if the product will not be used for an extended period.
 - The LED will show a constant green light when the battery is fully charged.
 - When the battery is in normal state/in operation, the LED flashes green at REGULAR intervals, namely 0.5 s ON, 4 s OFF.
 - When the battery requires charging (remaining charge <25%) the LED will flash orange/red at REGULAR intervals, namely 0.5 s ON, 4 s OFF.



NOTE! The battery has an in-built device that automatically switches it off when remaining charge is <20%. The LED is then extinguished. The battery must now be fully charged before the electronics can be used again.

Maintenance (recommended at least once per year)

Check that	Action
<p>General The walker feels firm/does not feel loose. The walker does not rattle during manoeuvres. The walker is level and all of its castors are in contact with the floor. The walker is not dirty.</p>	<p>Clean with lukewarm soap solution or alcohol-based cleaning agent (no petroleum products).</p>
<p>Arm rests Arm rests are intact and clean. Arm rest widening is functional.</p>	<p>Clean; replace if damaged. Replace lock knob.</p>
<p>Handle Grips are not damaged/dirty. Handle adjustment is functional.</p>	<p>Clean with lukewarm soap solution (no petroleum products). Replace handle grips. Fit lock knobs/plates as required.</p>
<p>Battery Check that the charging cable is connected to the control box. Check that the remote control is connected to the control box. Connect or fit new remote control as required. Check that the battery, actuators and control box are not loose.</p>	<p>Fit new cable; this must always be connected to the control box (IP65 classification). Connect; replace with new remote control as required. Refer to the wiring diagram in the Technical manual. Tighten; replace with new fasteners as required.</p>
<p>Height/width adjustment Raising and lowering are functional. The walker feels stable at maximum settings. There is no looseness between the vertical frame and bottom frame. Height adjustment clamps lock. The electric actuator must not feel loose. Height adjustment via remote control is functional. The electric actuator must run smoothly at a constant speed.</p>	<p>Fit new guide sleeves (in frame) or end plugs (in chrome tubes) as required. The technical manual shows the design and which fasteners must be checked. Contact the distributor if the parts cannot be tightened. Replace clamps. Tighten the attachment fitting concerned; replace bolts/lock nuts as necessary. Check that the battery/remote control/actuator are connected in accordance with the wiring diagram. Charge the battery. Contact customer services.</p>
<p>Frame parts There is no mechanical damage. There are no scratches. End plugs/lower frame fitted.</p>	<p>If damage is present, contact GATE's customer services. Touch up as necessary. Fit new end plugs.</p>
<p>Castors/brakes Castors roll easily/tread not damaged. The castors are tightly fastened to the lower frame. Castor brakes functional on all castors. Handbrake functional.</p>	<p>Clean or replace castors (NOTE! Castors are always fixed to the lower frame with thread locker or lock nuts. The castors are sealed and we do not recommend their dismantling; instead, replace the whole castor assembly). Tighten the castor bolt and fit locking nut or use thread locker (depends on model). Replace castor assembly. Adjust the brake or fit new castors.</p>

General safety/maintenance advice



- The Bure Walker may only be used:
- as a WALKING AID / STAND-UP AID.
 - INDOORS on HARD, LEVEL surfaces.

Before use, always check that:

- the product feels firm, secure and stable
- harnesses, belts and attachments are intact and undamaged

Wipe the walker and its armrests clean as necessary; use soap solution/surface disinfectant. Be aware of battery charge status (LED) – charge as necessary.

ID label

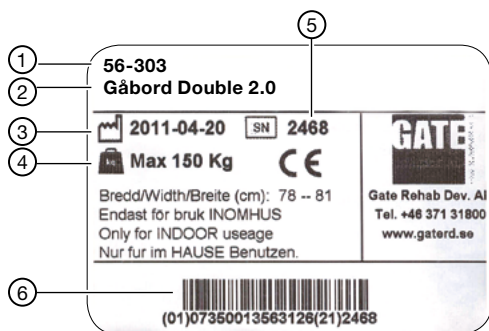

1. Part number
2. Product name
3. Date of manufacture
4. Max user weight
5. Serial number
6. EAN code

Recycling/Scrapping

When the product is no longer usable it should be recycled in accordance with legislation and regulations in the country concerned. All electrical parts including batteries must be removed and recycled as electrical components. (Ask your local recycling station for further information about how the different materials in the product (metals, plastics, electronics) should be recycled).

Warranty

We provide two years' warranty for manufacturing faults (does not apply to wear parts). For further information or enquiries please contact:



Gate Rehab Development AB
Industrigatan 2, SE-330 21 Reftetele, Sweden
Tel: +46 (0)371 31800
info@gaterd.com

Technical specifications

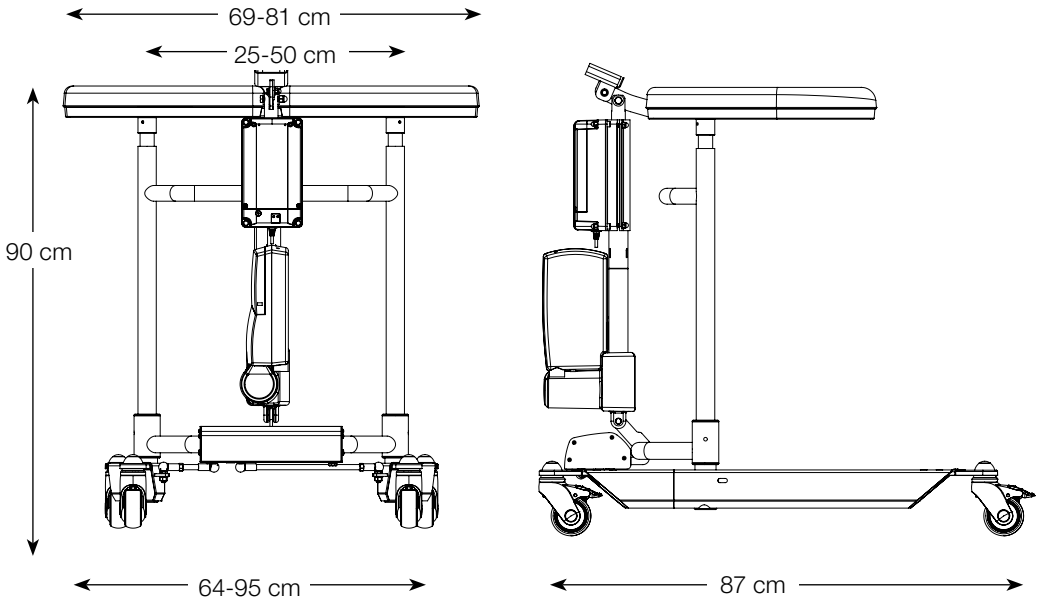

Dimensions apply to walkers with 125 mm castors.

Part No.	Product Width	Max user weight	Length	Height	Weight	Armrest/ internal dimension
56-303	69-95 cm	150 kg	87 cm	90-130 cm	40 kg	25-50 cm

CE CE marked according to MDD 93/42/EEC
The expected lifespan of this product = 8 years



WE DO BETTER.

Would you like to know more?

Contact us at: Tel: +46 371 31800
Gate Rehab Development AB
Industrigatan 2 | SE-333 75 Reftele
info@gaterd.se | www.gaterd.se



GATE COLLECTION