

Instructions for use



AmfibiTM

Hygiene chair

GATE

www.gate.it

Amfibi XL 56-204

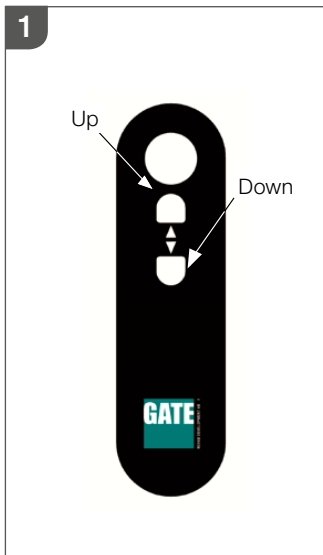

Raising/lowering the seat

The seat is raised/lowered using the remote control (see figure 1).



Manoeuvring may take place with the patient in the chair; make sure there is no risk of pinch injuries.

Audible signals during operations (warning symbol/N.B. symbol);

- 3 short buzzes means the battery must be recharged (chair can only be lowered).
- 1 short buzz means the battery is empty.

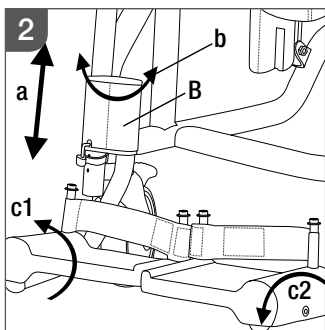

Foot support/heel restraint

a) The foot support can be adjusted in height by removing the clips (see figure 2) and moving the foot support to the desired height. Make sure to replace the clips (see figure 3).

b) The foot support can be swung to the side by grasping it at arrow B and lifting/swinging.

c) The foot support platform can be swung upwards (c1) and/or angled (c2) as desired.

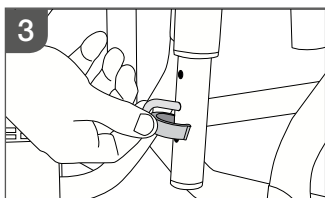

Safety *Read these instructions carefully before use.*

- Never stand on the Amfibi.
- The Patient Charge Nurse/Nurse Practitioner is responsible for ensuring that the product is suitable for its user.



Sanitary pan

The sanitary pan is slid into position from behind between the seat and wire guides as shown in figure 4.

Make sure the sanitary pan is slid into position above the wire guides. Also make sure that the pan is in the right position in relation to the seat/cut-out.



Locking the castors

Amfibi XL is fitted with three braked (grey pedal) castors with directional locking (green pedal). Figure 5 shows activation of castor functions. Braking via grey pedal – rolling and swiveling disabled. Locking via green pedal – wheels roll normally but cannot swivel.

Installation/adjustment of back-strap

Fasten the back-strap around the rear frame – lock using the side-release buckles. Adjust to the desired position. Make sure the cut-out for the armrest is aligned with the cut-out in the back-strap.

- Battery care – make a practice of always removing the battery from the control box and placing it in the charger when the chair is not used (especially overnight or when out of use for a day or two). The control box always consumes a small amount of electricity and the battery is then at risk of serious damage if it is not charged regularly.
- The user Weigh must not exceed 250 kg.
- When adjusting the height; make sure there is no risk of pinch injuries.



Installing the seat

The seat is easily attached with the clips underneath that snap onto the seat frame (see figure 6).



Moving the chair

We recommend using the handlebar whenever the chair must be moved (with/without a patient). The handlebar is designed so that the chair can be moved forwards and turned easily (see figure 7).



Locking the armrests

The armrest is locked in the extended position. To lift the armrest, pull out the pin (1) and raise the armrest (2).

- Observe caution on inclines and when passing over thresholds or similar.
- Never stand on the FOOTREST – tip risk.
- Battery charging must ALWAYS take place in dry spaces, never in wet rooms or similar.
- The chair must NEVER be used without a battery as this may damage the control box and electronics.
- The chair must NEVER be used UNDERWATER (in a pool or similar).

System calibration

If power is cut during operation or in direct connection with operations (within 5 seconds of the chair's having been manoeuvred) it may be necessary to reset/recalibrate the system. This is done to synchronize the actuator proximity sensors.

Calibration:

Press both of the remote control buttons UP/DOWN simultaneously for around 10 seconds until a beep is heard. Release the buttons. Press the the DOWN button and run the chair to its lowest position. Release the button. The system confirms the action with a buzzer. The system may then be used normally.



Battery installation/ removal

The battery is usually located in the control box and is held in place magnetically. Battery removal: Twist the battery 90° – pull it out. Installation: Slide the battery into the control box (figure 9). The battery is locked into position magnetically followed by a beep to signal everything is OK.



- Audible warnings when battery is installed;
- 2 long buzzes means calibration must be carried out (see above).
 - 5 short buzzes means the battery must be recharged before operations.

Charging the battery

Remove the battery from the control box and place it in the charger supplied. Connect the charger to the mains (red lamp lights up – charging). When the battery is fully charged the green lamp lights up. NOTE! Battery charging must always take place in dry spaces. The chair may NOT be used when the battery is removed – water may enter the control box and damage it.

Maintenance (annually)

The chair is fabricated from steel tubes (painted externally/internally) and aluminium. Exposed parts that are not painted are made of aluminium/stainless steel. The chair is cleaned in the normal manner (autoclave proof to 60 degrees (does not apply to control box and battery) and normal detergents). Take care to check that the product

Maintenance - Special check items

1. Armrest – check that slip protection/wrist protection are intact and secured.
2. Electric actuator/raise-lower: check the function of the remote control and that the electric actuator attachment devices are not loose.
3. Seat/soft seat – whole and without cracks. No sharp edges may be present.
4. Foot support platforms – whole and adjustable in the intended manner. Check that the clips are whole and properly fastened. Heel restraints must be in position at the back of each foot support platform.
5. Castors – must not be stiff or loose. Also check that the brakes work.
6. The Softbackrest should be without any damages in fabric or belts/locking mechanism.



Warranty

We provide a two-year warranty against any manufacturing defects (does not apply to wear parts).



Would you like to know more?

Contact us at:
Tel: +46 371 31800
Gate Rehab Development AB
Industrigatan 2 | SE-330 21 Reftele
info@gaterd.se | www.gaterd.se

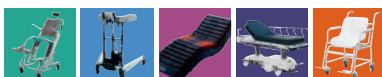

GATE COLLECTION